



TWD

150mm SQUARE TOP BUCKET TRAP

TWD150SQBT

Push-in series commercial floor drain for indoor and outdoor applications

Suitable for floor finishes - concrete tiled and resin.

Product Code:

TWD150SQBT

Specification:

Application:	Commercial Drainage
Floor:	Concrete / Tiled / Resin
Frame (mm):	150 x150
Outlet Diameter (mm):	89
Material:	SS 304
Load Class AS3996 (kg):	L15
Standards / Specification:	• WMTS-040 • AS3996 • AS4586
Secure Lock Grating:	Anti - Vandal Screw
Outlet Direction: Shape:	Vertical
Dimensions (mm):	Square
Weight (kg):	See Drawing
Ring Seal:	2.85
Features:	EPDM

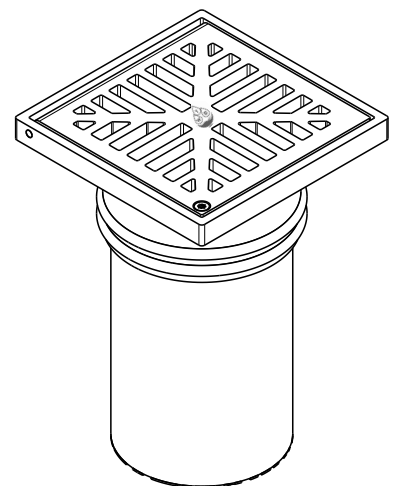
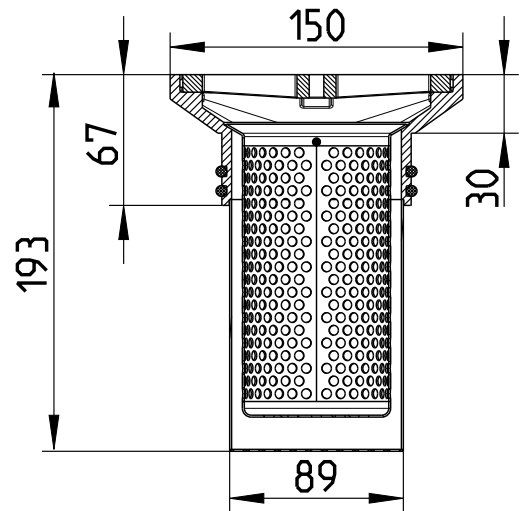

- Non-Slip.
- Removable Filter Basket.
- Secure Lock Grating.
- 110° Hinged Grating.
- Heel Safe Grating.
- Suitable for use with stainless steel, cast iron, copper, HDPE, PVC and PP pipe and fittings.

www.tradewastedrain.com

W
WaterMark
WMK 27044