

MICRON WH302A

CLASSIC 300 SERIES - TWIN WHOLE HOUSE FILTRATION SYSTEM

General Information

Engineered for mains water, the Classic 300 Series Twin Whole House Filtration System is designed to deliver clean, fresh water for your home or business. Its advanced twin-stage filtration process reduces sediment, chlorine, and by-products such as trihalomethanes (THMs) down to an exceptional 5 microns*, enhancing both taste and odour.

Built with UV-resistant, premium 316-grade stainless steel brackets and external cover, this system is made to withstand Australia's harsh outdoor conditions, ensuring long-lasting durability and peace of mind.

A specialised seal design prevents water bypass and ensures complete media contact, providing consistent, great-tasting water throughout your entire home or business.

Designed for mains water supply.



Features and Benefits

- High flow twin filtration for both commercial and residential use
- Standard size 4.5" x 20" housings — providing 100% more capacity than 4.5" x 10"
- Greater contact time, flow rates, longevity and chemical removal
- Suitable for small to large homes with 2 or more bathrooms
- 5 micron Sediment Pre-Filter removes larger particles like sand, dirt, rust, and debris from the water
- CTO Carbon Block Filter removes chlorine, volatile organic compounds (VOCs), pesticides, herbicides and other chemicals, improving taste and odour
- UV Resistant Marine Grade 316 Stainless Steel brackets and external cover
- Brass thread connection
- 1/4" top mount pressure gauge ports and bleed valve

Cartridge Replacement and Timeframe Suggestions

WH20-5SED 5 micron PP Sediment Filter cartridge to be replaced every 6 - 12 months.

WH20-CTO Coconut Shell Carbon Block Filter to be replaced every 6 - 12 months.

Version 1_Oct 2025

MICRON WH302A

CLASSIC 300 SERIES TWIN WHOLE HOUSE FILTRATION SYSTEM

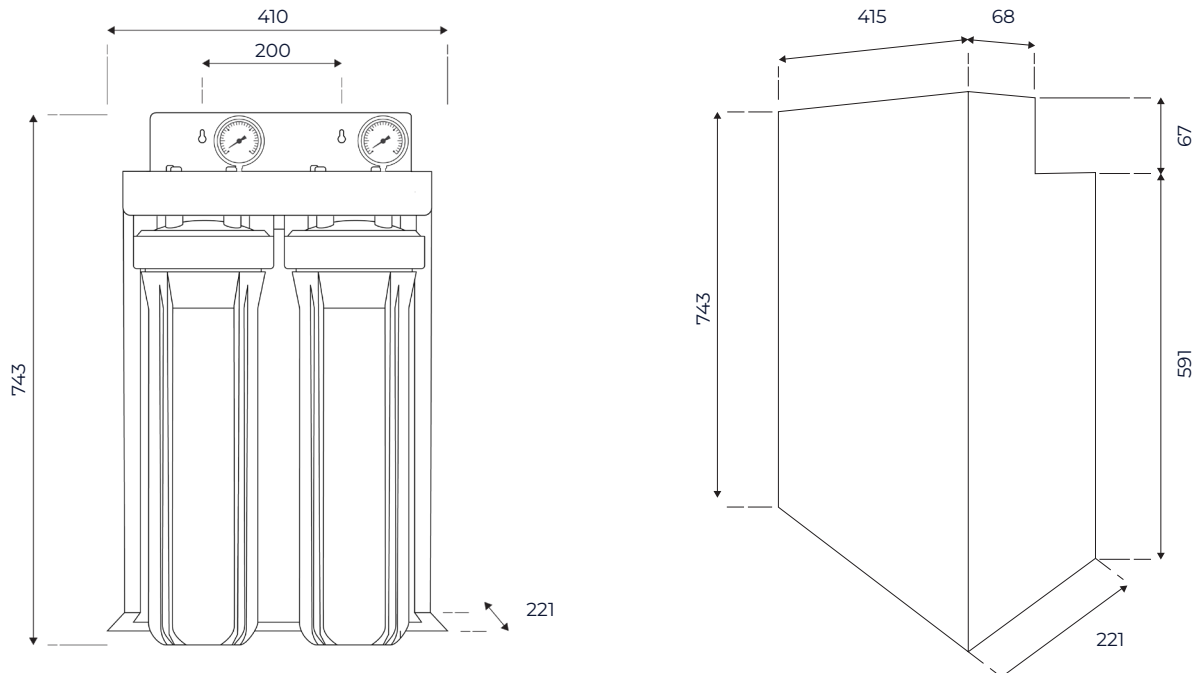

Measurements in millimetres

Classic 300 Series - Twin Whole House Filtration Specifications

Model	WH302A
Product Description	Classic 300 Series Twin Whole House Filtration System 1st stage: 5 micron PP Sediment Pre-Filter (Model: WH20-5SED) 2nd stage: CTO Coconut Shell Carbon Block Filter (Model: WH20-CTO)
Filtration Capacity	Removes dirt, sand, silt, rust and fine particles to nominal size Reduces chlorine, VOCs, chemicals, odour and unpleasant taste
Flow Rate	35L/min
Micron Rating	5 micron*
Min/Max Pressure	200-1600 kPa
Min/Max Temperature	4 - 42°C (must not freeze / cold water only)
Connection	Standard Port Size 1" - Brass Thread
External Cover	316 Marine Grade Stainless Steel mounting frame and cover
Cartridge Size	4.5" x 20"
Compatible Filter Cartridges	WH20 Series
Dimensions	With Cover: 743 mm (H) x 415 mm (L) x 221 mm (W)
Certification	WaterMark
Warranty	3 Years [^]

[^] 3 year warranty covering parts only, excluding cartridges. Use only genuine Micron Water Filters cartridges. Filter replacement timeframes are guidelines only and may vary with water quality and usage.

* Micron rating is nominal.