

WH1 Series

High Flow Whole House Single Water Filter System

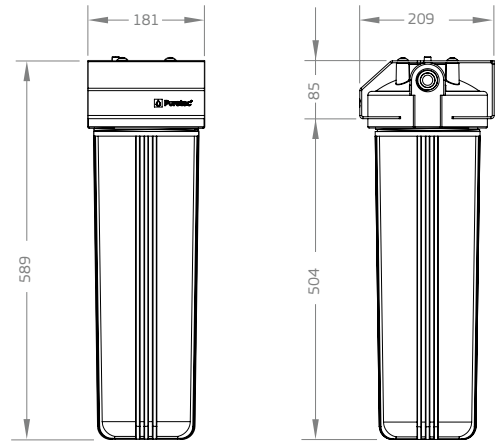

MAINS WATER



Front

Side

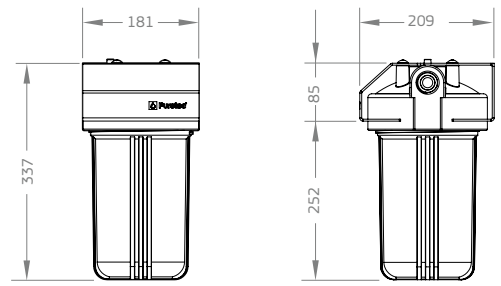

Front

Side

Note: All dimensions are in mm.

Parts Included

Registered Design



WH1-60
20" Single Water Filter System



CB10MP2
MaxiPlus
4.5" x 20"

Registered Design



WH1-30
10" Single Water Filter System



CB10MP1
MaxiPlus
4.5" x 10"



User guide

Specifications

Ordering Code	Pressure** (kPa)	Flow (Lpm)	Micron Rating*	Connection	Cartridge Size	Taste & Odour Reduction Cartridge
WH1-30	200-875	30	10	Lead-Free Brass 1" BSP [25 mm]	10"	CB10MP1
WH1-60	200-875	60	10	Lead-Free Brass 1½" BSP [40 mm]	20"	CB10MP2

Note:

Designed for mains water supplies. Min/Max Temperature: 0 - 52°C . Protect from freezing. No power required.

Warranty: Use only genuine Puretec replacement cartridge. ^10 year warranty is 1 year parts and labour, 9 years parts only. Excludes cartridges.

Note: No claims can be made based on the specifications and images in this document. The design, technology, colours, features and prices are subject to change. This document and all its contents are copyright protected. All rights are reserved, particularly alteration, translation and reproduction using electronic systems. This spec sheet has been designed to help make product selection easy. However due to the complex nature of water chemistry, we strongly encourage confirming any product selection with one of our team. We may need to perform a water analysis test to confirm contaminants in water. Caution: Do not use with microbiologically unsafe water or water of unknown quality without adequate disinfection before or after the system. Warranty: *Warranties in this document cover parts for the period stated and include cover for parts and labour for the first year where applicable, subject to approval. Excludes consumables. **Micron Rating is nominal. Our Water Filtration Specialists can provide you with advice to suit your needs. ***Where line pressure exceeds 520kPa, an approved pressure limiting device must be installed to comply with Australian & New Zealand Plumbing Standards. (Ref. AS 35001:2021, Clause 3.3.4). Maximum flow depends on cartridges, vessel, pressure, impurities etc.

